

Christopher Hart
Lancaster University

Construal Operations in Online Press Reports of Political Protests

To be published in C. Hart and P. Cap (eds.), *Contemporary Critical Discourse Studies*. London: Bloomsbury.

1. Introduction

One of the most successful new ‘schools’ or ‘approaches’ in CDS is represented by a body of work applying insights from Cognitive Linguistics (Chilton 2004; Dirven, Frank and Putz 2003; Hart 2010, 2011a; Hart and Lukeš 2007). This body of work includes but is not limited to Critical Metaphor Analysis (e.g. Charteris-Black 2004; Koller 2004; Musolff 2004). At the theoretical core of this ‘Cognitive Linguistic Approach’ (CLA) are the notions of *conceptualisation* and *construal*. Conceptualisation is the dynamic cognitive process involved in meaning-making as discourse unfolds. This process entails language connecting with background knowledge and global cognitive abilities to yield local mental representations. To the extent that the CLA focuses on the relation between discourse and conceptualisation, it addresses the cognitive import of (ideologically imbued) linguistic representations (cf. Stubbs 1997: 106). Construal refers to the different ways in which a given scene, guided by language, can be conceptualised. Alternative ‘construal operations’ are reliant on different cross-domain cognitive systems and realise different (ideological) discursive strategies. In this chapter, I discuss some of the specific construal operations which, invoked in the audience, are the locus proper of ideological reproduction in discourse. I do so in the context of two contrasting online news texts reporting on the G20 protests in London, 2009.¹ In section 2, I outline a typology of construal operations which may be taken as an (evolving) heuristic for analyses conducted from the perspective of the CLA. In sections 3 through to 5 I discuss different construal operations in turn and show how they contribute to the ideological and (de)legitimizing quality of discourse on political protests. Finally, in section 6, I offer some conclusions.

2. The Cognitive Linguistic Approach

The incorporation of Cognitive Linguistics in CDS is now a well-established practice. I will not rehearse again here the motivations for, or arguments in favour of, using Cognitive

Linguistic methods of analysis in CDS (see Hart 2011b, in press). Rather, I will outline a framework for the CLA and illustrate its utility through analyses of selected examples. The CLA focusses on the relationship between representations in text and cognition. Its major concern is with the cognitive import of linguistic (lexical and grammatical) constructions presented in texts. In so doing, it responds to a significant issue in CDS which we can label the problem of cognitive equivalence (cf. Stubbs 1997; O'Halloran 2003; Widdowson 2004; Billig 2008). The issue concerns the extent to which alternative linguistic structures have any (measurable) effects on our cognition of the situation or event being described (see Hart 2013a/b). This is a significant issue for CDS for if structures in discourse are to play any ideological role in shaping and sustaining social structures, then they must first and foremost function in shaping and sustaining the cognitive structures (ideologies) which at root motivate, support and legitimate social action (Chilton 2005; van Dijk 1993).

In the CLA, cognitive import is approached in terms of the conceptual structures and processes which linguistic constructions invoke in the minds of the audience.² These short-term structures are built up in working memory for purposes of local understanding during discourse. They may be subsequently discarded. However, strengthened by repeated patterns of activation as well as other linguistic and contextual factors, they may alternatively come to constitute long-term conceptual structures in the form of frames and conceptual metaphors which provide the cognitive basis of ideologies (Dirven, Frank and Putz 2003; Hart 2010; Koller in press). Cognitive Linguistics is therefore especially useful for CDS in so far as it is able to “lay bare the structuring of concepts and conceptions” (Dirven, Frank and Putz 2003: 4) which constitute ideologies. In particular, Cognitive Linguistics addresses “the structuring within language of such basic conceptual categories as those of space and time, scenes and events, entities and processes, motion and location, and force and causation” (Talmy 2000: 3). These are, of course, precisely the ideational categories that CDS has traditionally been interested in for the way that they are represented in discourse may carry some ideological weight (Kress and Hodge 1993; Van Dijk 1995). According to the CLA, though, this ideological potential of language (to create and sustain patterns of belief and value which serve specific interests) is only realised through the conceptualisations which representations in discourse invoke. The aim of the CLA is then to disclose the particular conceptual parameters along which ideology may be enacted.

A major claim of Cognitive Linguistics, and thus the CLA in CDS, is that language serves as a prompt for an array of cognitive processes. These processes are conceptual in nature where language is conceived as a system of conventionalised form-meaning pairings or ‘symbolic assemblies’ (Langacker 2008). Crucially, this applies to both lexical and grammatical units. This follows from a view of language in which there is no principled distinction between grammar and lexicon; all linguistic knowledge is conceptual in nature. Words and constructions are therefore equally symbolic. The difference between them is a matter only of degree of abstraction. From this perspective, grammatical constructions are in and of themselves meaningful by virtue of the (highly abstract) images that they invoke.

A further central claim of Cognitive Linguistics is that language is embodied. That is, language emerges out of the kind of experiences we have with our bodies and the physical environment we inhabit (Lakoff and Johnson 1999). This includes, for example, visuo-spatial, kinetic and proprioceptive experience as well as observations that make up a naïve physics. As a consequence, language is not seen as an autonomous mental faculty cut off from other areas of cognition and the cognitive processes involved in language use are not considered unique to language (Croft and Cruse 2004). They are, rather, manifestations of more general cognitive processes which are also found to function in other non-linguistic domains of cognition, including perception (ibid.). The construal operations invoked by language are thus grounded in domain-general cognitive systems which also underpin analogous perceptual processes (ibid.). Language, on this account, can direct us to ‘see’ the situation or event being described in different ways. These alternative construals, as ‘ways of seeing’, depend on parameters of conceptualisation including what we chose to look at, how closely we examine it, which elements we pay most attention to, where we see the scene from, and whether we observe it directly or through some refracting medium (Langacker 2008: 55). Crucially, for CDS, such construal operations serve, in specific contexts, to realise alternative ideological *discursive strategies* (Reisigl and Wodak 2001) as the construals they produce encode a particular, legitimating or delegitimizing, representation of reality.³ In the CLA, four types of discursive strategy are proposed: *structural configuration, framing, identification* and *positioning*.⁴ The various construal operations involved in realising these strategies are presented, also in relation to the cognitive systems upon which they rely, in Figure 1.⁵

System \ Strategy		Gestalt	Comparison	Attention	Perspective
		Structural Configuration	Schematisation		
Framing	Construal operations		Categorisation		
			Metaphor		
Identification				Figure/Ground	
				Granularity	
				Viewing Frame	
Positioning					Point of View
					Deixis

Figure 1. Construal operations in the CLA

Structural configuration is the most basic strategy. In structural configuration, realised through schematisation, the speaker imposes on the scene described an abstract image-schematic representation. This skeletal representation provides an holistic structure to the situation or event which captures relations such as topology, sequence and causation. Schematisation also defines the participant roles involved in an event. This construal operation is grounded in the same system that supports Gestalt perception – our ability to perceive a complex scene as the sum of its parts. This basic schematic representation is then subject to various forms of ‘elaboration’ in which the skeletal structure is ‘fleshed out’ to provide further content specifications (Langacker 2002: 103). Framing strategies are an example of such elaboration. Framing strategies concern the attribution of particular qualities to the entities, actors, actions and processes that make up a situation or event as alternative categories and metaphors, which as a function of the frame-based knowledge they access carry different evaluative connotations or logical entailments, are apprehended in their conceptualisation.⁶ Framing strategies are grounded in our ability to compare domains of experience. Identification strategies concern the presence and relative salience of social actors in the conceptualisation. They are realised in various construal operations which Langacker (2002) groups together under the banner of ‘focal adjustments’. These operations are manifestations of more general attentional abilities. Ultimately, however, identification strategies can be accounted for by shifts in point of view and are thus ancillary to positioning strategies (Hart, forthcoming). Positioning strategies, then, pertain to the manipulation of (metaphorical) space and the relative ‘coordinates’ of actors and events within the conceptualisation. They are realised in the vantage point from which the scene is construed and the location, orientation and distance of other discourse elements relative to this ‘ground’ (or ‘deictic centre (cf. Chilton 2004; Cap 2013)). Positioning is not restricted to the domain of literal space but occurs also in spatialised conceptualisations of time and modality (ibid.). In what follows, I discuss each of these construal operations in turn and demonstrate, in the context of contrasting online newspaper reports of the 2009 London G20 protests, how they may function ideologically in contributing to the realisation of alternative discursive strategies.⁷

3. Structural Configuration

Structural configuration is a strategy by means of which speakers impose on the scene described a particular image-schematic representation. Image schemas are abstract, holistic knowledge structures derived from repeated patterns in early, pre-linguistic experience (Johnson 1987; Mandler 2004). They are naïve theories about the way the world works (ibid.). One ubiquitously instantiated image schema is the action-chain schema (or ‘billiard ball’ model) in which there is a transfer of energy from an agent to a patient (sometimes via an instrument) resulting in a change in state to the patient. Image schemas later come to form the meaningful basis of many lexical and grammatical units. The action

chain schema, for example, underpins the prototypical transitive clause which describes a physical interaction between two or sometimes three participants (Langacker 1991: 238). Here, the agent, encoded as Subject, is the *source* of the energy flow whilst the patient, encoded as (direct) Object, is the energy *sink*. If present, the instrument, encoded as indirect Object in a prepositional phrase, constitutes an energy *transmitter*. In discourse, such image schemas get called up by their lexical and grammatical counterparts to constitute our understanding of the basic internal topological and relational structure of the entity, event or situation under conception. Consider (1) which invokes the full action chain schema modelled in Figure 2.

- (1) At one point, [a black-clad man in the crowd_{agent}] [struck_{action^a}] [an officer_{patient}] with [a long pole_{instrument}] (*Telegraph*, 1 April 2009)

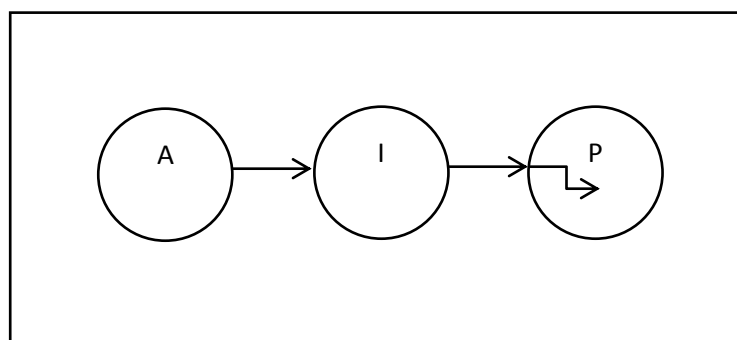

Figure 2. Asymmetrical action schema (including instrument)

In (1), the interaction between the protester and the police officer is construed as unidirectional based on an *asymmetrical* action schema in which the transfer of energy flows from the protester (agent) to the police officer (patient) via an instrument, a long pole. The protester as the energy source is the initiator of the interaction and therefore bears sole responsibility for the violent encounter. Crucially, however, from a critical perspective, language has the facility to recruit alternative image schemas to conceptualise the same (kind of) situation and thus impose upon it alternative, ideologically vested, construals. By way of contrast, then, consider (2) in which the encounter between police and protesters is construed as bidirectional based on a *reciprocal* action schema.

- (2) By about 8pm, [running battles_{action^r}] between [riot police_{agent}] and [demonstrators_{agent}] were taking place across London Bridge. (*Guardian*, 1 April 2009)

The schema invoked to conceptualise the scene in (2) – modelled in Figure 3 – involves a mutual transfer of energy. No one participant can thus be assigned the status of agent with the other cast in the role of patient (there is no instrument in this example). Rather, both participants are agentic in the process and responsibility for the violent event is therefore equally apportioned.

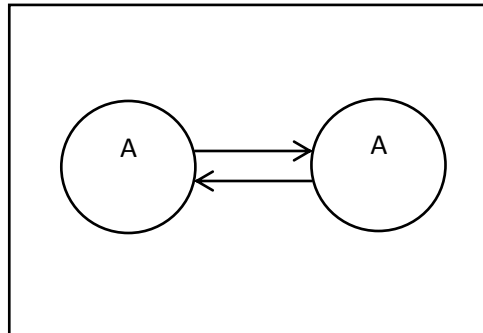

Figure 3. Reciprocal action chain

Examples (1) and (2) represent alternative structural configuration strategies. In (1) the event is configured in a way which conforms to the classic ideological square (van Dijk 1998) with the 'in-group' – the police from the perspective of the *Telegraph* – represented sympathetically as victims of violence and the 'out-group' – the protesters – represented punitively as perpetrators of violence. The same one-sidedness is not seen in (2) which pays more heed to the role of the police in the violence that ensued.

In the two G20 articles, both papers actually prefer asymmetrical rather than reciprocal action schemas. However, there is a systematic difference in terms of who gets cast in which role within these schemas.⁸ In the *Telegraph*, it is primarily the protesters who are cast in the role of agent as in (1). In the *Guardian*, by contrast, the police are more often cast in the role of agent as in (3). This contrast further represents alternative strategies in structural configuration in which different degrees of attention are given to the part played by the police in the violence that unfolded.

- (3) ... [at least 10 protesters sitting down in the street close to the Bank of England_{patient}] were left with bloody head wounds after [being charged_{action^a}] by [officers with batons_{agent}] at around 4.30pm. (*Guardian*, 1 April 2009)

Although the *Guardian*, in examples like (3), clearly does recognise the contributory role of the police in the violence that occurred, it nevertheless employs several strategies which

serve to mitigate the police action. One such strategy is schematising an event which in reality would almost certainly have involved some form of physical interaction between an agent and a patient as a purely motion event. This alternative structural configuration strategy is instantiated in (4). The schema invoked is not an action schema but represents instead an alternative domain of familiar experience in which one entity (a trajector) is seen to move along a path defined relative to a landmark. The particular motion schema invoked by (4) is modelled in Figure 4.⁹ In this schema, the police are represented as following a path of motion which finds them located inside the protesters' camp. The vector in the image schema thus represents a trajectory rather than a transfer of energy with the terminus of the vector a location rather than another human participant. The schematisation therefore glosses over any physical effect of the event which may have been felt by the protesters. Neither does it point to any impact on the landmark.

- (4) Then, at around 7pm, [the police _{trajector}] [moved in _{motion}] on [the climate camp _{landmark}] (*Guardian*, 1 April 2009)

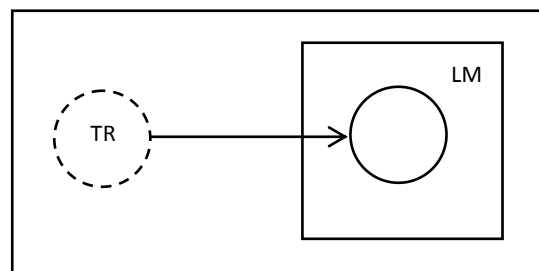

Figure 4. motion into landmark schema

(5) similarly encodes a motion event but in this instance, with the protesters as the entity whose location is at issue, the impact of the force of the motion is recognised. Whilst (4), then, designates a purely motion event without reference to any resistance from or effect on the landmark, (5) designates a violent form of motion which results in damage to the landmark. The schema invoked by (5) is modelled in Figure 5. The stepped arrow represents the resultant impact of the event on the landmark.

- (5) [A small number of demonstrators _{trajector}] [forced their way into _{motion^{io1}}] [the building on Threadneedle Street _{landmark}] near the Bank of England after smashing windows ... (*Telegraph*, 1 April 2009)

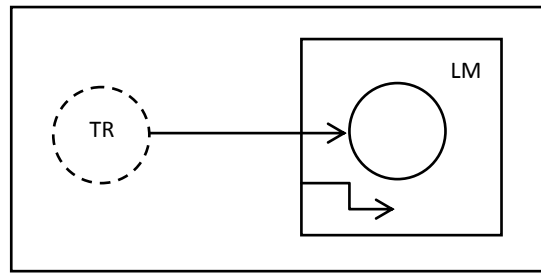

Figure 5. motion with impact on landmark schema

The euphemistic sense of ‘move in’ in (4) is close to being metaphorical. In the CLA, metaphor is a well-known conceptual device for concealing or accentuating certain aspects reality and thereby dampening or heightening affect (e.g. Charteris-Black 2004; Chilton 2004). We turn to metaphor as a framing device in the next section.

4. Framing

Frames for cognitive linguists are areas of culture-specific experience encoded in long-term semantic memory (Fillmore 1982). They stand as the conceptual background against which particular concepts are understood. Crucially, from a critical perspective, when any one element of a frame is introduced in discourse, the remainder of that frame becomes automatically activated (ibid. p. 111). In framing strategies, speakers are therefore able to make conceptually salient particular areas of knowledge (whilst simultaneously suppressing others). The specific knowledge areas accessed, in turn, give rise to patterns of inference and evaluation.

Framing strategies are grounded in a general ability to compare domains of experience. The most basic framing device is categorisation. The act of categorisation involves comparison in so far as the entity, event or situation in question is judged as belonging to the same class of prior experiences to which a particular linguistic expression has been previously applied (Croft and Cruse 2004: 54). The ideological function of categorisation can be seen most clearly in the categorisation of social actors (van Leeuwen 1996). The most obvious instance of ideological difference in the G20 data comes in the headlines of the two newspapers:

(6) Rioters loot RBS as demonstrations turn violent (*Telegraph*, 1 April 2009)

(7) G20 protests: riot police clash with demonstrators (*Guardian*, 1 April 2009)

Although both examples represent instances of functionalisation in van Leeuwen's model, there is a clear difference in framing between them. In (6) the categorisation accesses a riot frame which contains entries to do with violence and vandalism. The categorisation is consequently more likely to invite condemnation. The categorisation in (7), by contrast, accesses a demonstration frame containing entries for marching and chanting etc. Categorising the actors involved as *rioters* versus *demonstrators* thus connotes opportunistic criminality rather than an organised display of political discontent.

The ideological function of metaphor as a framing device is now well-recognised (Lakoff 1991, 2003; Chilton and Lakoff 1995; Chilton 1996; Santa Ana 2002; Koller 2004; Musolff 2004). Metaphorisation involves comparing experience, via a mapping, in two distinct domains (Lakoff and Johnson 1980, 1999). Typically, a more abstract social domain (the *target domain*) is compared to a more familiar domain of experience (the *source domain*) encoded in image schemas and/or cognitive frames in order to provide structure and facilitate reasoning procedures within the target. Ideology comes in to play as the choice of source domain mediates and shapes our understanding of the target situation making way for certain 'logical' deductions as *entailments* of the metaphor (ibid.). Metaphor permeates 'everyday' discourse as much as political discourse and the same or similar metaphors may be as much a feature of natural language, where they are relatively innocuous, as they are of institutionalised Discourses, where they may or may not take on particular ideological qualities. From a critical perspective, the metaphors we should be primarily concerned with are those which are specific to the Discourse in question, which function in specific ways in political contexts, or which represent context-specific variants of metaphors that naturally make up the conceptual system.

Two well-documented conceptual metaphors are anger is hot liquid inside a container (Kövecses 2000) and argument is war (Lakoff and Johnson 1980). The dominant metaphors employed in the two G20 texts seem to be specific variants of these. Ideologically, however, there is a difference as to which is used by each newspaper. The dominant metaphor in the *Telegraph* can be expressed as violence is hot liquid inside a container. This conceptual metaphor is instantiated in the following examples:

- (8) ... a largely peaceful demonstration spilled over into bloody violence in the centre of London. (*Telegraph*, 1 April 2009)
- (9) Clashes later erupted at Mansion House Street and Queen Victoria Street near the Bank. (*Telegraph*, 1 April 2009)

The image invoked is of a potentially dangerous liquid previously contained 'boiling up' and escaping from the container. In (9) this is realised specifically in the image of a volcano

erupting. Such a conceptualisation is likely to invite an emotive response and, further, suggests the need to control the liquid. In the target domain this equates to the controversial police tactic known, presumably by no coincidence, as 'kettling'.¹⁰ The particular metaphorical construal invoked by (8) and (9) thus seems to rationalise and sanction the police handling of events.

The dominant metaphor in the *Guardian*, by contrast, can be expressed as violence is war and is instantiated in the following examples:

- (10) The G20 protests in central London turned violent today ahead of tomorrow's summit, with a band of demonstrators close to the Bank of England storming a Royal Bank of Scotland branch, and baton-wielding police charging a sit-down protest by students. (*Guardian*, 1 April 2009)
- (11) Much of the protesting, from an estimated 4,000 people in the financial centre of the capital, was peaceful, but some bloody skirmishes broke out ... (*Guardian*, 1 April 2009)
- (12) By about 8pm, running battles between riot police and demonstrators were taking place across London Bridge (*Guardian*, 1 April 2009)

The vocabulary highlighted belongs, with lesser or greater degrees of conventionality and semantic looseness, to the domain of war. According to Semino, war metaphors in political discourse "tend to dramatize the opposition between different participants ... who are constructed as enemies" (2008: 100). Crucially, however, such militarising metaphors seem to suggest some degree of purpose and precision on the part of the protesters as well as the police. It may even be argued that the use of *storm* in particular (in contrast, say, to *invade*) appraises the protesters' action as being born of noble intent.¹¹ Ideologically, then, the violence is war metaphor found in the *Guardian* is more sympathetic to the protesters' cause than the naturalising metaphor violence is hot liquid in a container found in the *Telegraph*.

5. Positioning (and Identification)

The final strategy we will discuss in this chapter is positioning and its interrelation with identification. Positioning strategies rely on a more general capacity to adopt a (simulated) perspective. Specifically, positioning strategies relate to where we situate ourselves and where other entities are located relative to this 'coordinate' (cf. Chilton 2004; Cap 2013). They are effected through conceptual shifts in point of view and deixis. Positioning

strategies can pertain to positions in space but also metaphorical 'positions' in time as well as in epistemic and axiological 'space' (ibid.). Positioning can also be semantic, where a simulated point of view forms part of the conventionalised meaning of a given linguistic expression, or it can be pragmatic where point of view corresponds with the conceptualiser's actual situatedness or what they take as their broader, deictically-specified spatial, temporal, epistemic and axiological 'ground'. In this chapter we focus very narrowly on spatial point of view as encoded in the conventionalised semantic values for particular grammatical constructions (for further discussion see Hart, forthcoming; for a more pragmatic account see Cap, this volume). Here, positioning strategies can be seen to co-occur in a mutually dependent way with structural configuration strategies where many, if not all, grammatical constructions include as part of their conventionalised meaning an image schematic representation and a particular point of view from which the scene described is 'seen' (Langacker 2008: 75). This simulated position is part of the conceptualisation that a given construction conventionally invokes and thus forms part of the meaning of that construction.

The most familiar modality in which we necessarily adopt a particular perspective is vision. The argument from Cognitive Linguistics, recall, is that the conceptual processes involved in language are manifestations of more general processes which find parallel expression in other cognitive functions, including vision. There are thus obvious links between the meaning-making processes we describe in linguistic approaches to CDS and the visuo-spatial variables described in multimodal media and discourse studies (e.g. Kress and van Leeuwen 2006). In this section, I therefore adopt the vocabulary of film studies to account for certain positioning phenomena in language. The reader should recognise, however, that this is not a metaphor but is motivated by the fact that the kind of visuo-spatial experience captured in a grammar of visual design constitutes precisely the kind of embodied experience which language builds upon in the first place. Several point of view operations could be discussed here. However, we restrict ourselves to two particularly productive ones: panning and zoom.

5.1. Panning

The point of view operation of panning underpins several grammatical distinctions, including the distinction between asymmetrical and reciprocal action schemas as well as distinctions in information sequence and voice within them. Let us take first the distinction between reciprocal and asymmetrical transactive constructions. Asymmetrical constructions seem in some sense to be one-sided; that is, they seem to ask the conceptualiser to 'take sides'. Reciprocal constructions, by contrast, are more neutral and ask the conceptualiser to recognise the active role of both participants in the process. I argue that this is due, in part, to the alternative points of view that these constructions encode. The distinction between reciprocal and asymmetrical transactive constructions

represents a point of view shift best characterised as *panning* where the ‘camera’ swings around the scene on a horizontal axis to present a view from alternative anchorage points. This is modelled in Figure 6 where the broken vectors represent potential directions of energy transfer which may be instantiated in particular conceptualisations. The broken circles (C) represent potential (cardinal) points of view from which the scene can be construed. This idealised cognitive model is instantiated in different ways in specific conceptualisations as modelled in Figure 7.

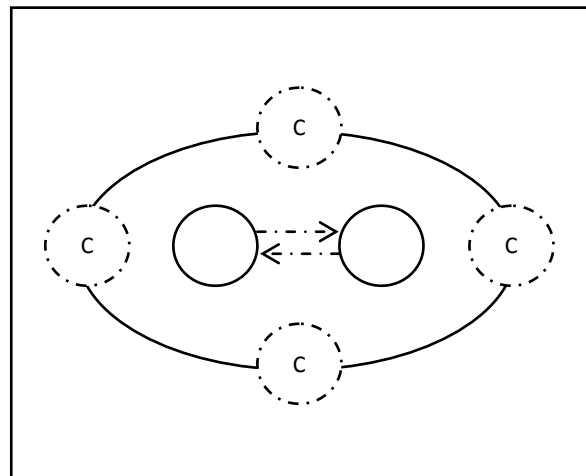
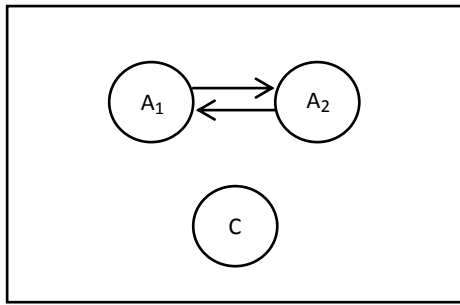

Figure 6. Panning

In reciprocal constructions the point of view encoded is one in which the simulated position of the conceptualiser is such that their orientation (measured as an imagined vector following their sagittal axis) runs perpendicular to the vectors representing the transfer of energy between participants. Two positions are available in this mode as modelled in Figure 7 (a) and (b). In the construals invoked by reciprocal constructions, then, the conceptualiser is literally occupying the middle ground between both participants. The metaphorical sense in which this construction asks the conceptualiser to adopt a more neutral stance, I suggest, is a product of this spatial perspective. In asymmetrical constructions, the point of view encoded is from a position such that the conceptualiser’s orientation is in-line with the vector representing the transfer of energy from one participant to another. Again, two positions are available with the conceptualiser located either at the tail end or the head end of the vector as in Figure 7 (c) and (d). In asymmetrical constructions, then, the conceptualiser is literally positioned on the side of one participant in opposition to the other and the metaphorical sense in which asymmetrical constructions seem to ask the conceptualiser to ‘see’ things from ‘one side’ in confrontation with the other is again a function of this spatial positioning strategy.



(a) Reciprocal action schema

$a_1 = \text{Given}, a_2 = \text{New}$

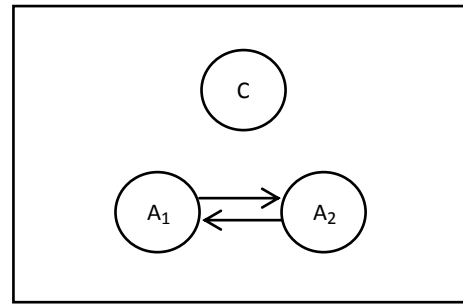

(b) Reciprocal action schema

$a_1 = \text{New}, a_2 = \text{Given}$

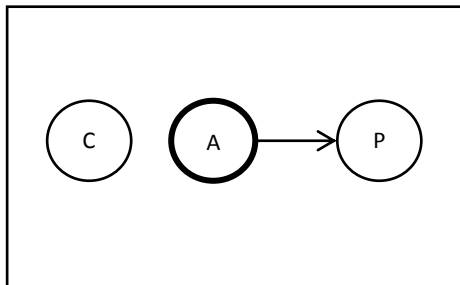

(c) Asymmetrical action schema

Active voice

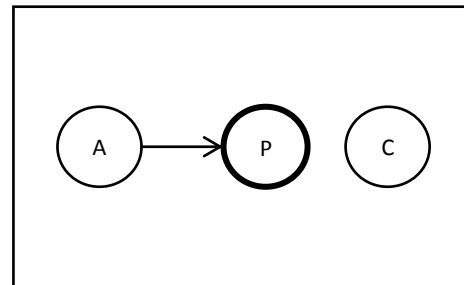

(d) Asymmetrical action schema

Passive voice

Figure 7. Spatial points of view

The question then is what determines the point of view in reciprocal constructions as being that in Figure 7 (a) or 7 (b) and similarly what determines the point of view in asymmetrical constructions as being that in 7 (c) or (d). The answer, I suggest, is information structure and voice respectively. Let us take reciprocal constructions first. It is well known that information sequence in discourse reflects the speaker's assessment of what constitutes Given information and what constitutes New information (Halliday 1967). Typically, elements introduced earlier in the clause represent given information whilst later elements represent new information. In news discourse, however, this seems to be reversed and, especially in headlines, new information comes first. This is perhaps due to the urgency of delivering 'newsworthy' information in order to gain the reader's attention. Nevertheless, because of the canonical ordering of Given and New and the direction of writing in English, given information becomes associated with spatial left and new information becomes

associated with spatial right (van Leeuwen 2005: 201). Compare, then, (13) and (14). Assuming a structural configuration in which protesters are assigned as participant a_1 and protesters as participant a_2 , (13) can be characterised as encoding a point of view as in Figure 7 (a) placing the police to the left of the conceptualiser and protesters to the right. Conversely, (14) encodes a point of view as in Figure 7 (b) locating the protesters to the left of the conceptualiser and the police to the right.¹²

(13) [Riot police_{new}] [clash with_{action}^r] [demonstrators_{given}]. (*Guardian*, 1 April 2009)

(14) [Protesters_{new}] [clashed with_{action}^r] [police_{given}] around the Bank of England. (*Telegraph*, 1 April 2009)

Now, ideologically, reciprocal constructions, although relatively neutral compared to asymmetrical constructions, are not entirely value-free. Kress and van Leeuwen (2006) argue that what is spatially left is conceived as 'commonsensical' whilst what is spatially right is conceived as 'contestable'. Thus, (13) may be interpreted as calling into question police behaviour during the protests whilst (14) treats their role as normative and calls into question instead the behaviour of the protesters.

In asymmetrical constructions, only one participant is activated and thus the transfer of energy is unidirectional from an agent to a patient. Asymmetrical constructions require a voice choice between active and passive. Whether the point of view is that presented as in Figure 7 (c) or (d) is a function of this voice choice. The active voice encodes a view from the perspective of the agent as in 7 (c). The passive voice, by contrast, encodes a view from the perspective of the patient as in 7 (d). It is here that positioning can be seen to interact with identification. In the active voice, the agent is in the foreground of the conceptualiser's attention. That is, they are the figure whilst the patient is the ground (Talmy 2000).¹³ In the passive voice, this is reversed and the patient is the figure and the agent the ground.¹⁴ This is represented in Figure 7 by the bold outline. Consider the difference between (15) and (16).

(15) [Riot police wielding batons_{agent}] [managed to force [the crowds_{patient}] back_{force}]. (*Telegraph*, 1 April 2009)

(16) [Officers standing on the steps at the front of the Bank of England_{patient}] [were pelted_{action}^a] [with fruit_{instr}] [as [protesters_{agent}] scrambled beneath them_{circ}]. (*Telegraph*, 1 April 2009)

(15) may be said to encode a view as in Figure 7 (c) whilst (16) can be characterised as encoding a view as in 7 (d). Based on this analysis, we may need to reinterpret the ideological function of the active/passive distinction. In orthodox interpretations, the active voice is said to highlight the role of the agent in the process whilst the passive voice is analysed as distancing the agent and thereby detracting attention from relations of causality (REFS). Ideologically, the active voice is thus said to be used to draw attention to negative behaviours of the out-group whilst the passive voice is used to direction attention away from negative behaviours of the in-group. Observations of voice function, however, are often made in relation to isolated examples (cf. Widdowson 2004).

On the analysis presented here, the role of voice is to position the conceptualiser with respect to participants in the event in contrasting ways. In the active voice, the conceptualiser sees the scene from the perspective of the agent in a position of conflict with the patient. In the passive voice, the conceptualiser sees the scene from the perspective of the patient in a position of antagonism with the agent. On this analysis, the active voice does indeed highlight the role of the agent by locating them in the conceptual foreground but places the conceptualiser literally and metaphorically on their side. We should therefore expect to find positively construed behaviours of the in-group expressed most frequently in the active voice as in (15) where the event is positively construed as a force event pertaining to the location of the patient rather than being construed as an action event (see Hart 2013b).¹⁵ Similarly, whilst the passive voice does initially distance the agent, it locates the conceptualiser on the side of the patient and, thus, in the dynamic conceptualisation invoked the energy transfer from the antagonistic agent (sometimes via an instrument) is construed as directed not only at the patient but toward the conceptualiser too. Active versus passive constructions, then, seem to include as part of their meaning a deictic dimension. The ideological function of the passive voice can therefore be characterised as something more akin to a spatial proximation strategy (Cap 2006, 2013, this volume). If correct, we should thus expect to find negatively construed behaviours of the out-group directed at the in-group most frequently expressed in the passive voice as in (16).¹⁶ Such a pattern of distribution, which we seem to find in the *Telegraph*, would conform to the classic ideological strategy of positive-Self versus negative-Other representation.¹⁷ The interpretation presented here would therefore be greatly strengthened by a comprehensive and detailed corpus-based analysis of voice alternates across different newspapers to see whether their distribution fits with expectations given what we already know about the ideological orientations of different news institutions.

5.2. Zoom

The final construal operation we will discuss is *zoom*. This point of view shift takes place on the distal rather than horizontal (or anchorage) plane. It underpins a number of grammatical constructions relating to the expression of causal ity. Zoom concerns the

distance of the camera from the scene depicted. The greater the zoom, the less of the scene is able to be captured. The camera must then focus on particular parts of the scene. Conversely, a wide-angle lens with negative zoom is able to capture much more. Language similarly has the facility for conceptualisations which zoom in or out on the scene described resulting in a more or less restricted viewing frame. This is modelled in Figure 8.¹⁸ 8 (a) represents the idealised cognitive model for zoom with three potential points of view: long shot, medium shot and close-up. 8 (b) – (d) represent the specific viewing frames which result from instantiations of these points of view. The viewing frame is that portion of evoked conceptual content currently in focus. The most obvious means by which language zones in on particular facets of the reference situation is through explicit mention of that portion (Talmy 2000: 258). Here, again, positioning and identification can be seen to interact. Indeed, one of the ideological functions of zoom is to conceptually background causation including in the form social actors. In discourse on political protests, this is often seen in relation to the causes of injuries. Consider (3) reproduced below as (17) in contrast to (18):

- (17) ... [at least 10 protesters sitting down in the street close to the Bank of England_{patient}] were [left with bloody head wounds_{result}] [after [being charged_{action^a}] by [officers with batons_{agent}] at around 4.30pm_{circ}]. (*Guardian*, 1 April 2009)
- (18) One man, [bleeding from the head_{result}], was repeatedly seen to apparently goad officers. (*Telegraph*, 1 April 2009)

(17) represents a medial shot. The viewing frame covers the full action chain invoked. The resultant of the interaction, injuries, is expressed as part of a verb phrase in the main clause and the cause of these injuries is fully spelled out in the circumstantial clause. This is modelled in Figure 8 (b). In (18), by contrast, only the resultant of the interaction is expressed. There is no reference at all as to how the injuries might have been sustained. (18) represents an extreme close-up with the viewing frame covering only the final element in the action chain. This is modelled in Figure 8 (c). The action chain is still invoked since we know that injuries are the result of some form of interaction and the agent therefore remains within the *scope of attention* (Langacker 2008). However, located beyond the purview of the current viewing frame they are unspecified. Close-up versus medial shots, then, serve to exclude or include issues of causation. Ideologically, we find the cause of injuries to protesters included within the viewing frame in (17) but excluded in (18). (17), in other words, presents a point of view from which police violence is not seen.

If one function of zoom is to crop the viewing frame in order to conceal aspects of causation, another is to expand the viewing frame in order to include within it some mitigating causal circumstance. In this case, the point of view is that of a long-shot. Consider (19) and (20):

(19) [Hundreds of protesters cheered as office equipment including a printer was carried out of the building _{cause}] ... before [riot police wielding batons _{agent}] [managed to force [the crowds _{patient}] back _{force}]. (*Telegraph*, 1 April 2009)

(20) [Police _{agent}] [used [truncheons and batons _{instr}] to beat back _{action^a}] [the protesters _{patient}] [each time they surged forward _{cause}] (*Guardian*, 1 April 2009)

Any event is not in reality temporally and causally discrete but is, rather, part of an ongoing sequence of causal interactions. In extending the viewing frame, as in both (19) and (20), the conceptualisation takes in some preceding event which is recognised as a directly causal or at least mitigating factor in relation to the main event. This is modelled in Figure 8 (d).¹⁹ Ideologically, then, we find in both the *Telegraph* and the *Guardian* examples of events in which the police are agents construed in this way but no similar examples vis-à-vis events in which protesters are agents. This serves to present police actions as provoked, retaliatory or restorative. They are no longer the source of the energy transfer. By contrast, protester actions, in not being seen from this distal point of view, are construed as unprovoked instances of gratuitous violence.²⁰

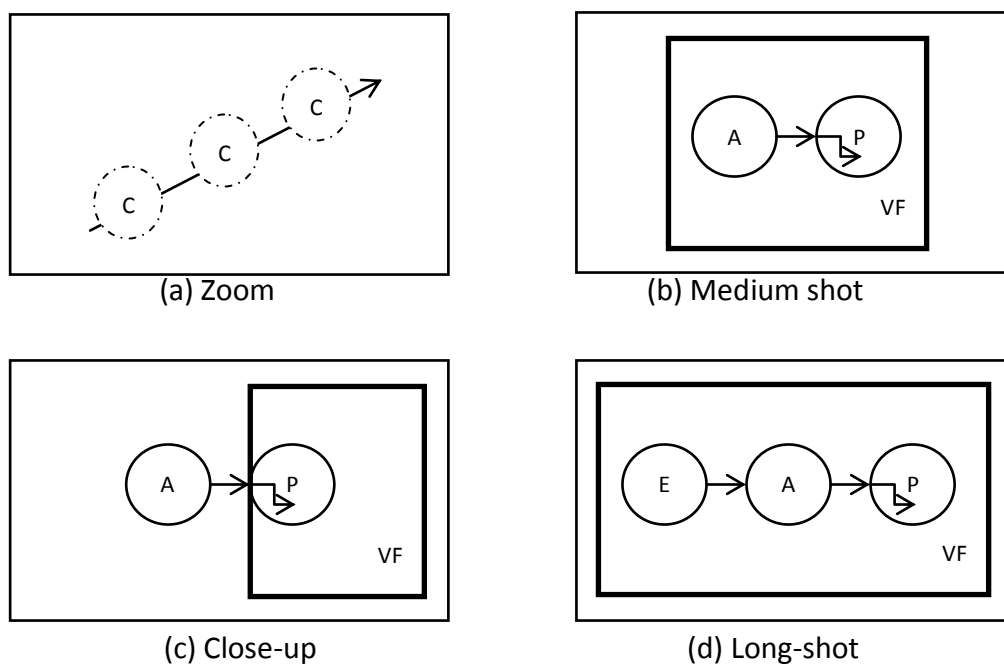

Figure 8. Zoom and viewing frames

6. Conclusion

In this chapter, I have outlined a Cognitive Linguistic Approach to CDS highlighting a number of strategies and construal operations responsible for the enactment of ideology in discourse. I have done so in the context of online press reports of political protests and the London G20 protest in particular. The main aim of this approach is to address the conceptual import of linguistic representation and to disclose the ideological qualities of those conceptualisations invoked in discourse by linguistic expressions. Several claims have been made about the nature of conceptual counterparts to specific linguistic constructions/alternations. Some of these claims remain more speculative than others at this stage. However, I hope to have presented an account which is at least internally coherent psychologically plausible. The Cognitive Linguistic Approach is inherently interdisciplinary, relying on notions from linguistics, discourse studies and cognitive psychology. The last section on positioning suggests the need for further interdisciplinarity through a greater degree of collaboration between linguistic and multimodal approaches to discourse studies and perhaps also the need to reverse the direction of influence that we currently find between them. Empirically, I have pointed to a number of ideological differences in the conceptualisations invoked by the *Telegraph* and the *Guardian* to construe the violence that occurred at the G20 protests. The most striking observation here is that the *Telegraph* virtually ignores any possibility of police violence whilst the *Guardian* is more balanced adhering neither to a discourse of police violence but nor to one of police innocence.

References

- Billig, M. (2008), The language of critical discourse analysis: The case of nominalization. Discourse & Society 19: 783-800.
- Cap, P. (2006), Legitimization in Political Discourse, Newcastle: Cambridge Scholars Press.
- Cap, P. (2013), Proximisation: The Pragmatics of Symbolic Distance Crossing, Amsterdam: John Benjamins.
- Charteris-Black, J. (2004), Corpus Approaches to Critical Metaphor Analysis, Basingstoke: Palgrave Macmillan.
- Chilton, P. (1996), Security Metaphors: Cold War Discourse from Containment to Common House, New York: Peter Lang.
- Chilton, P. (2004), Analysing Political Discourse: Theory and Practice, London: Routledge.

- Chilton, P. (2005), 'Missing links in mainstream CDA: Modules, blends and the critical instinct', in R. Wodak and P. Chilton (eds.), A New Research Agenda in Critical Discourse Analysis: Theory and Interdisciplinarity, Amsterdam: John Benjamins, pp. 19-52.
- Chilton, P. and Lakoff, G. (1995), 'Foreign police by metaphor', in C. Schäffner and A.I. Wenden (eds.), Language and Peace, Aldershot: Ashgate, pp. 37-60.
- Croft, W. and Cruse, D.A. (2004), Cognitive Linguistics, Cambridge: Cambridge University Press.
- Dirven, R., Frank, R. and Putz, M. (eds.) (2003), Cognitive Models in Language and Thought: Ideology, Metaphors and Meanings, Berlin: Mouton de Gruyter.
- Fillmore, C. (1982), 'Frame semantics', in Linguistics Society of Korea (eds.), Linguistics in the Morning Calm, Seoul: Hanshin Publishing Co., pp. 111-37
- Hart, C. (2010), Critical Discourse Analysis and Cognitive Science: New Perspectives on Immigration Discourse, Basingstoke: Palgrave.
- Hart, C. (ed.) (2011a), Critical Discourse Studies in Context and Cognition. Amsterdam: John Benjamins.
- Hart, C. (2011b), 'Moving beyond metaphor in the Cognitive Linguistic approach to CDA: Construal operations in immigration discourse', in C. Hart (ed.), Critical Discourse Studies in Context and Cognition, Amsterdam: John Benjamins, pp. 171-192.
- Hart, C. (2011c), 'Force-interactive patterns in immigration discourse: A Cognitive Linguistic approach to CDA', Discourse & Society 22, 3, 269-286.
- Hart, C. (2013a), 'Event-construal in press reports of violence in political protests: A Cognitive Linguistic Approach to CDA', Journal of Language and Politics 12, 3, 400-423.
- Hart, C. (2013b), 'Constructing contexts through grammar: Cognitive models and conceptualisation in British Newspaper reports of political protests', in J. Flowerdew (ed.), Discourse in Context, London: Continuum, pp. 159-184.
- Hart, C. (in press), 'Cognitive Linguistics and Critical Discourse Analysis', in E. Dabrowska and D. Divjak (eds.), Handbook of Cognitive Linguistics, Berlin: Mouton De Gruyter.
- Hart, C. (forthcoming), Discourse, Grammar and Ideology: Functional and Cognitive Perspectives, London: Bloomsbury.
- Hart, C. and D. Lukeš (eds.) (2007), Cognitive Linguistics in Critical Discourse Analysis: Application and Theory, Newcastle: Cambridge Scholars Publishing.
- Johnson, M. (1987), The Body in the Mind: The Bodily Basis of Meaning, Imagination, and Reason, Chicago: University of Chicago Press.

- Koller, V. (2004), Metaphor and Gender in Business Media Discourse: A Critical Cognitive Study, Basingstoke: Palgrave.
- Koller, V. (in press), 'Cognitive linguistics and ideology', in J.R. Taylor and J. Littlemore (eds.), Companion to Cognitive Linguistics. London: Continuum.
- Kövecses, Z. (2002), Metaphor and Emotion: Language, Culture, and Body in Human Feeling, Cambridge: Cambridge University Press.
- Kress, G. and Hodge, R. (1993), Language as Ideology, 2nd edn., London: routledge and Keegan Paul.
- Kress, G. and van Leeuwen, T. (1996), Reading Images: The Grammar of Visual Design, 2nd edn., London: Routledge.
- Lakoff, G. (2001), 'Metaphor and war: The metaphor system used to justify the war in the gulf', Journal of urban and cultural studies 2, 59-72.
- Lakoff, G. (2003), Metaphor and war again, Available from <http://www.alternet.org>.
- Lakoff, G. and Johnson, M. (1980), Metaphors We Live By, Chicago: University of Chicago Press.
- Lakoff, G. and Johnson, M. (1999), Philosophy in the Flesh: The Embodied Mind and its Challenge to Western Thought, New York: Basic Books.
- Langacker, R. (1991), Foundations of Cognitive Grammar, vol. II: Descriptive Application, Stanford: Stanford University Press.
- Langacker, R. (2002), Concept, Image, and Symbol: The Cognitive Basis of Grammar, 2nd edn., Berlin: Mouton de Gruyter.
- Langacker, R. (2008), Cognitive Grammar: A Basic Introduction, Oxford: Oxford University Press.
- Mandler, J. (2004), The Foundations of Mind: Origins of Conceptual Thought, Oxford: Oxford University Press.
- Musolff, A. (2004), Metaphor and Political Discourse: Analogical Reasoning in Debates about Europe, Basingstoke: Palgrave Macmillan.
- O'Halloran, K. (2003), Critical Discourse Analysis and Language Cognition, Edinburgh: Edinburgh University Press.
- Reisigl, M. and Wodak, R. (2001), Discourse and Discrimination: Rhetorics of Racism and anti-Semitism, London: Routledge.

- Santa Ana, O. (2002), Brown Tide Rising: Metaphors of Latinos in Contemporary American Public Discourse, Austin: University of Texas Press.
- Semino, E. (2008), Metaphor in Discourse, Cambridge: Cambridge University Press.
- Stubbs, M. (1997), 'Whorf's children: Critical comments on critical discourse analysis (CDA)', in A. Ryan and A. Wray (eds.), Evolving Models of Language, Clevedon: British Association for Applied Linguistics, pp. 100-116.
- Talmy, L. (2000), Toward a Cognitive Semantics, Cambridge, MA.: MIT Press.
- van Dijk, T.A. (1993), 'Principles of critical discourse analysis', Discourse & Society 4, 2, 243-289.
- van Dijk, T.A. (1995), 'Discourse analysis as ideology analysis', in C. Schäffner and A.I. Wenden (eds.), Language and Peace, Ashgate: Aldershot, pp. 17-36.
- van Dijk, T.A. (1997), 'Cognitive context models and discourse', in M. Stamenow (ed.), Language Structure, Discourse and the Access to Consciousness, Amsterdam: John Benjamins, pp. 189-226.
- van Dijk, T.A. (1998), Ideology: A Multidisciplinary Approach, London: Sage.
- van Dijk, T.A. (2010), Discourse and Context: A Socio-Cognitive Approach, Cambridge: Cambridge University Press.
- van Leeuwen, T. (1996), 'The representation of social actors', in C.R. Caldas-Coulthard and M. Coulthard (eds.), Texts and Practices: Readings in Critical Discourse Analysis, London: Routledge, pp. 32-70.
- van Leeuwen, T. (2005), Discourse and Practice: New Tools for Critical Discourse Analysis, Oxford: Oxford University Press.
- Widdowson, H. (2004), Text, Context, Pretext: Critical Issues in Discourse Analysis, Oxford: Blackwell.

¹ The data is intended as purely illustrative with only qualitative analysis being presented. The contribution of the chapter is to outline the CLA as a particular framework for CDS. This is not to say, however, that this framework cannot be combined with Corpus Linguistic techniques to harvest further quantitative insights in a larger-scale empirical investigation. Neither is it to say that the framework is restricted in its utility to investigations of discourse on political protests (cf. Hart 2011b/c).

² This is in contrast to van Dijk's socio-cognitive approach in which the mental models which guide discourse production are theorised in propositional terms (van Dijk 1997, 1998, 2010).

³ Following Reisigl and Wodak (2001), discursive strategy is defined as a more or less intentional / institutionalised plan of discourse practices whose deployment ultimately achieves some social action effect. They are interpreted here as involving both a linguistic and a conceptual dimension as they are performed through particular locutions but bring about perlocutionary effects only through the conceptualisations that those locutions evoke.

⁴ The typology of discursive strategies presented in the CLA is not intended to compete with the one detailed in the discourse-historical approach (DHA). The two schools are concerned with different levels of meaning. Broadly, the strategies identified in the CLA operate at a lower-level compared to those outlined in the DHA. They may thus be thought of as contributing to or supporting in different ways the higher-level strategies defined in the DHA.

⁵ This typology supersedes the one presented in previous work (Hart 2011c, 2013a/b).

⁶ It should be noted that these strategies should not be taken as discrete and incapable of intersection. Rather, they are often co-extant in discourse, may be mutually dependent, and sometimes merge into one and other. Hence, the term *typology* is favoured over *taxonomy* (see Reisigl, this volume). To give an example, in categorising a scene, the speaker necessarily imposes on it a particular image-schematic representation. At the same time, in imposing a particular internal structure the speaker defines the scene as belonging to a higher-level category. The distinction between them can be seen, however, where the same basic schema is elaborated in different ways. For example, the U.S. HOUSE frame and the Russian DOM frame both instantiate a CONTAINER schema but, when applied metaphorically in international relations discourse to structure the concept of NATION, invoke subtly different construals as a function of the culture-specific encyclopaedic knowledge bases that they encode (Chilton 1996).

⁷ Around 35,000 people attended the initial G20 protests in London on 28th March 2009 with 5,000 people involved in the 'G20 Meltdown' protest outside the Bank of England on 1st April. A Royal Bank of Scotland

branch was also broken into and a 'climate camp' set up outside the European Climate Exchange on Bishopsgate. The protests, which were targeting a range of policy issues pertaining to capitalism and climate change, witnessed outbreaks of violence and police use of a controversial crowd control technique known as 'kettling'. One bystander, Ian Tomlinson, died after being beaten by a Metropolitan Police Officer Simon Harwood. The data presented below is taken from online reports published in *The Guardian* and *The Telegraph*. These papers take alternative political stances and appeal to different audiences with the papers and their readers likely to hold more liberal versus more conservative values respectively. Both papers focus on the violence that occurred at the protest. However, some subtle differences in conceptualisation can be seen which reflect, reinforce or contribute to constructing alternative Discourses of civil disorder. The data is available at: <http://www.telegraph.co.uk/finance/g20-summit/5089870/G20-protests-Rioters-loot-RBS-as-demonstrations-turn-violent.html> and <http://www.guardian.co.uk/world/2009/apr/01/g20-summit-protests>. Accessed 26.04.2013.

⁸ See Hart (2013a) for a basic quantitative analysis of the distribution of different schemas in this data.

⁹ This schema also provides the meaning of the lexical item *enter* (Langacker 2008: 32-33).

¹⁰ Kettling involves complete enclosure of protestors by police cordon for given periods of time, often without access to toilets and water etc., followed by partial cordoning allowing protestors to leave the scene only by specific designated routes.

¹¹ Evidence in support of the positive prosody of *storm* comes from its use in relation to the police in the *Daily Mail* two days following the protests: "Riot police storm G20 protesters' squats ..." (*Daily Mail*, 3 April 2009).

¹² The assignment of participants as A_1 and A_2 is arbitrary. If we assign them the other way around then (13) would invoke a point of view as in 7 (b) rather than 7 (a) and (14) would invoke a point of view as in 7 (a) rather than 7 (b). The point, however, is that there would still be a point of view shift which results in a reversed left/right alignment relative to the conceptualiser.

¹³ Positioning can also be seen to interact with identification in other point of view operations. For example, a bird's eye view, as encoded in certain types of metonymy and multiplex-to-uniplex construals, results in a loss of granularity (see Hart, forthcoming). Similarly, the kind of dynamic attention involved in expressions of fictive motion is analogous to a tracking shot.

¹⁴ In the agentless passive voice, the AGENT may be within the scope of attention but outside the current viewing frame (see Hart, forthcoming for further discussion).

¹⁵ The use of *managed to* also suggests a positive evaluation of a valiant restorative effort.

¹⁶ Although the main clause in (16) is an agentless passive construction, the AGENT of the action is strongly implied in the circumstantial clause.

¹⁷ In line with this macro-strategy, ostensibly negative behaviours of the in-group are either not mentioned or reconstructed in legitimating terms, for instance, schematised as FORCE or MOTION event rather than an ACTION event. At the same time, ostensibly positive behaviours of the out-group are either not mentioned or reconstructed in delegitimizing terms.

¹⁸ For purposes of illustration, the INSTRUMENT is left out of these models but it should be recognised that in each case there would be an INSTRUMENT intermediate in the energy transfer between AGENT and PATIENT.

¹⁹ In 8 (c) the cause event (E) is presented as a single THING but it would, of course, have its own internal structure.

²⁰ It is worth noting here some important differences between (19) and (20). In (19), the main event is a FORCE event whilst in (20) it is an ACTION event (compare force back with beat back). (20) thus attributes a greater degree of violence to the police. However, the action is still encoded as a reaction and is therefore mitigated. There is also a difference in information structure. In (19) the CAUSE is expressed first whilst in (20) it is only expressed at the end of the utterance. Thus, (19) keeps the CAUSE conceptually salient throughout whilst in (20) it only comes into focus later.